

Positioning, Cisco ONE Migration and Ongoing Innovation

Brownfield Scenarios

Key Questions

- Investment Protection: Are Cisco ONE customers with existing Catalyst/wireless purchases entitled to Cisco DNA?
- Cisco DNA upgrade: Can existing Cisco DNA customers upgrade to a higher function DNA tier?
- Offer Evolution: How do the Cisco ONE perpetual offers on existing Catalyst switches & wireless evolve going forward?

Cisco ONE Investment Protection

More Value with Cisco DNA

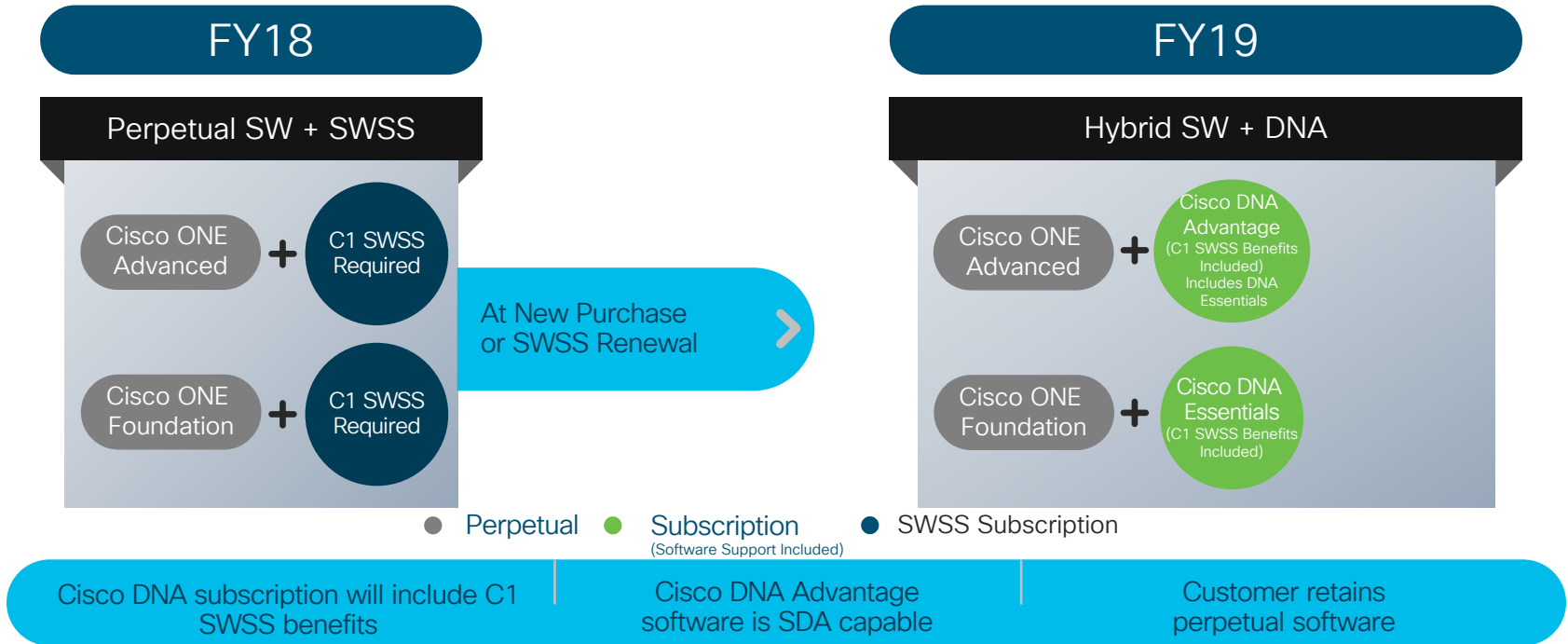

Get Cisco DNA and software support for the price of SWSS

*Routing Cisco ONE Advanced customers will get Cisco DNA Essentials

Cisco ONE Investment Protection

Enterprise Networking (Routing, Switching, Wireless)

FY18

FY19

Perpetual

Cisco ONE
Advanced

+

C1 SWSS
Required

Cisco ONE
Foundation

Subscription

Cisco ONE
Advantage

Cisco DNA
Advantage

Cisco DNA
Essentials

Perpetual

Cisco ONE
Advanced

+

DNA
(C1 SWSS
Benefits
Included)

Cisco ONE
Foundation

Subscription

Cisco DNA
Premier

Cisco DNA
Advantage

Cisco DNA
Essentials

● Perpetual ● Subscription (Software Support Included) ● SWSS Subscription

Cisco DNA Attach with C1 Purchase | Free Cisco DNA Center appliance*

*300K List in Cisco DNA SW purchase

Cisco DNA ongoing innovation

Cisco DNA upgrade: To higher level Cisco DNA tier

Transactional method

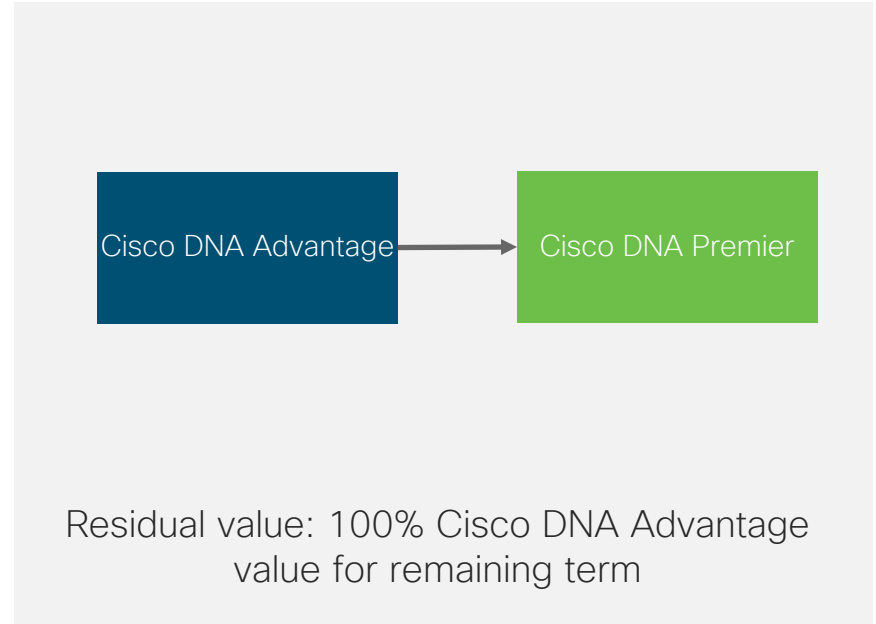
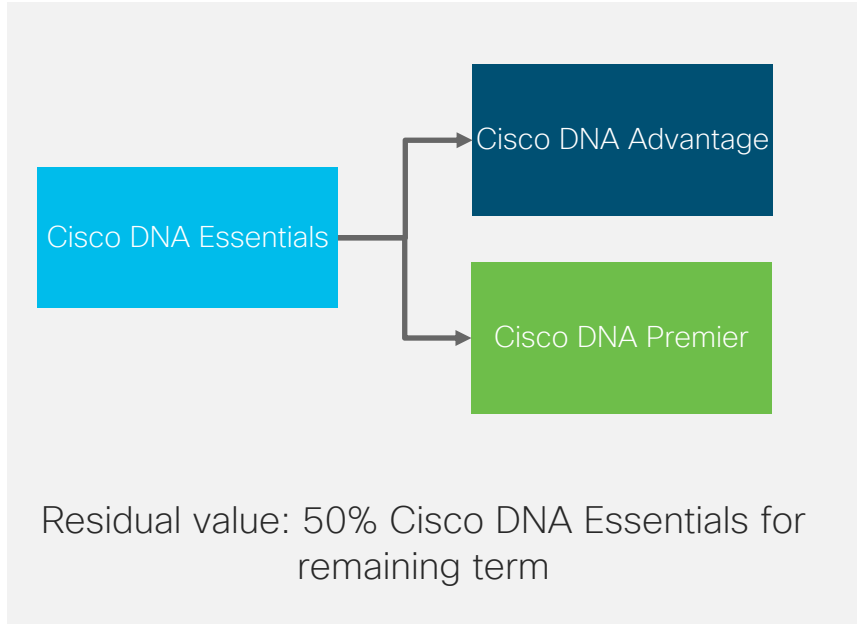

Promotional Credit for Cisco DNA Mid Term Upgrade (Non Std Deal)

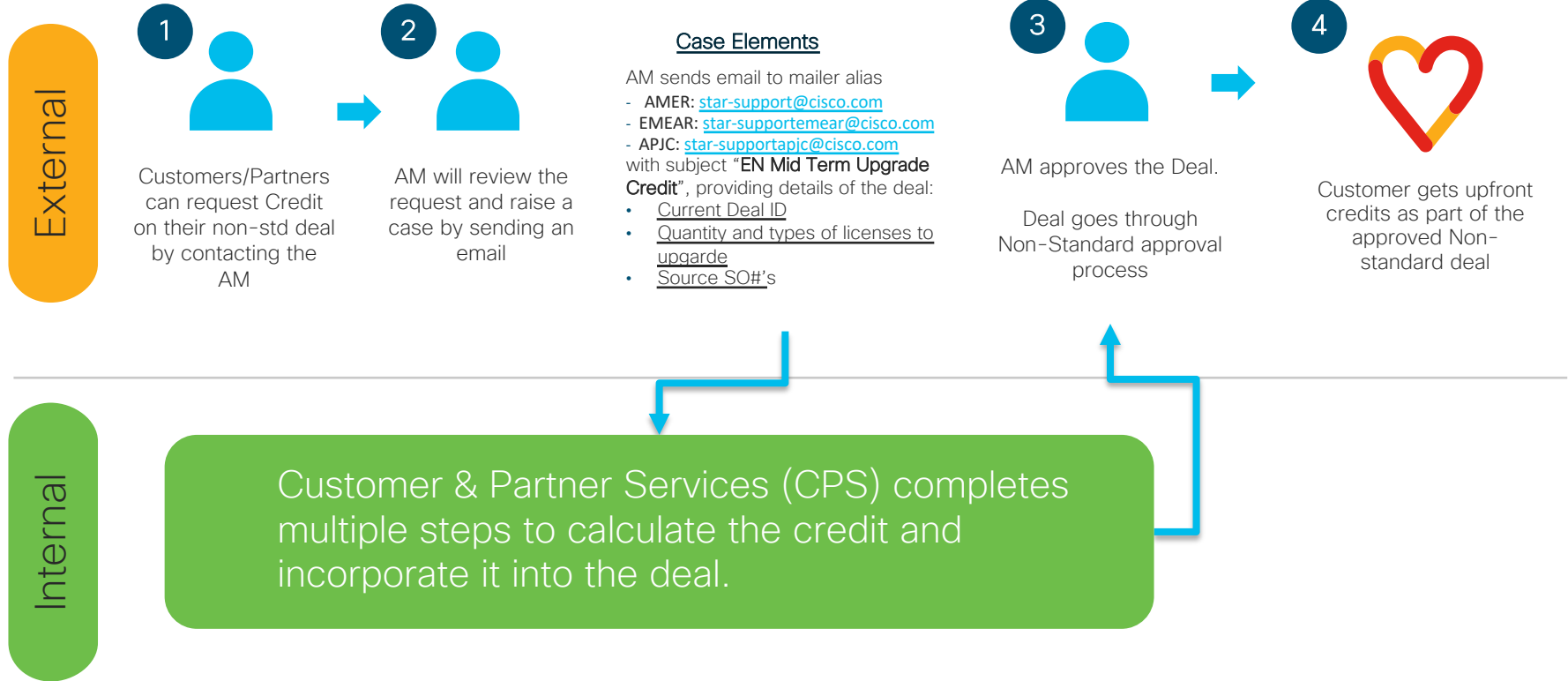

How does Cisco ONE evolve for existing Catalyst Platforms?

■ Term
■ Term
■ Perpetual

Old Model

Current Model

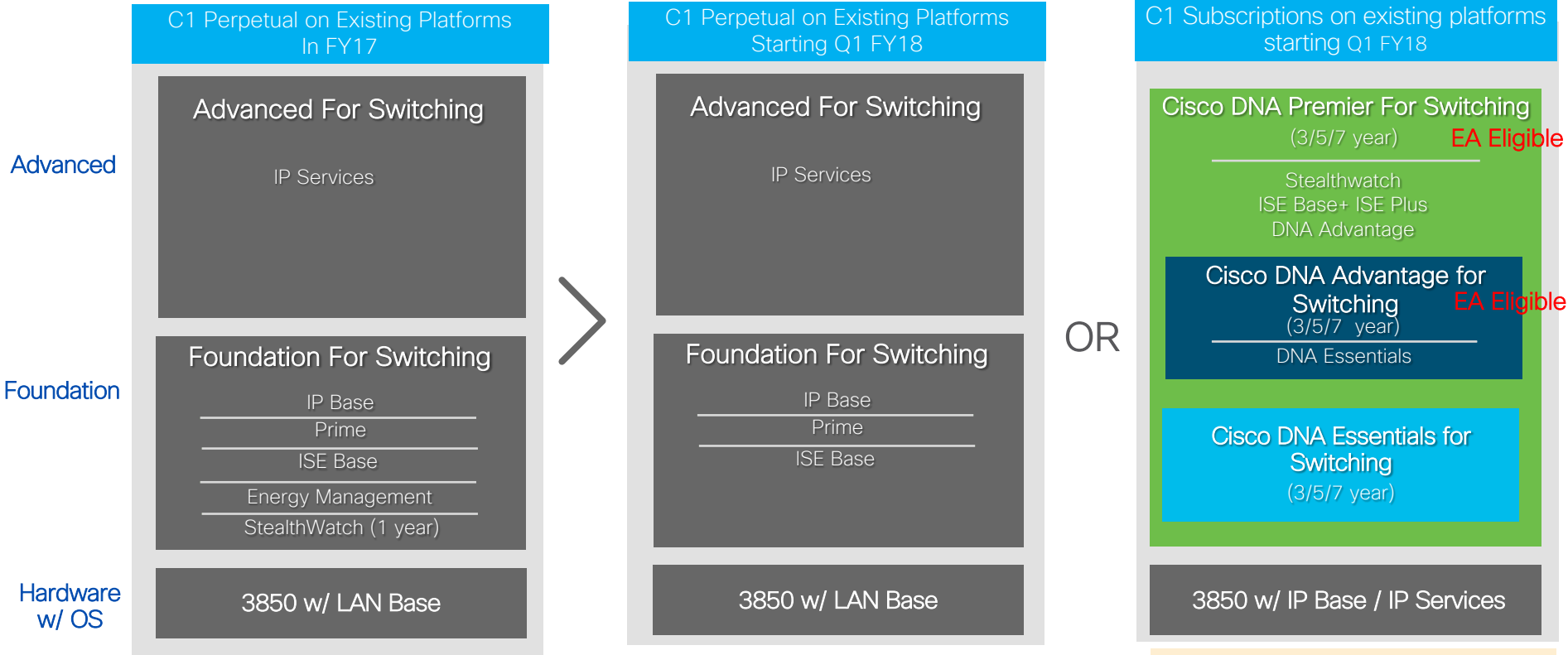

- Stealthwatch 1 year & Energy management retired from perpetual suite

- Similar model to Cat9k
- No OS portability.
- No SWSS for OS. SNTC covers OS.

What do Customers Buy?

What You Need for SDA or Assurance

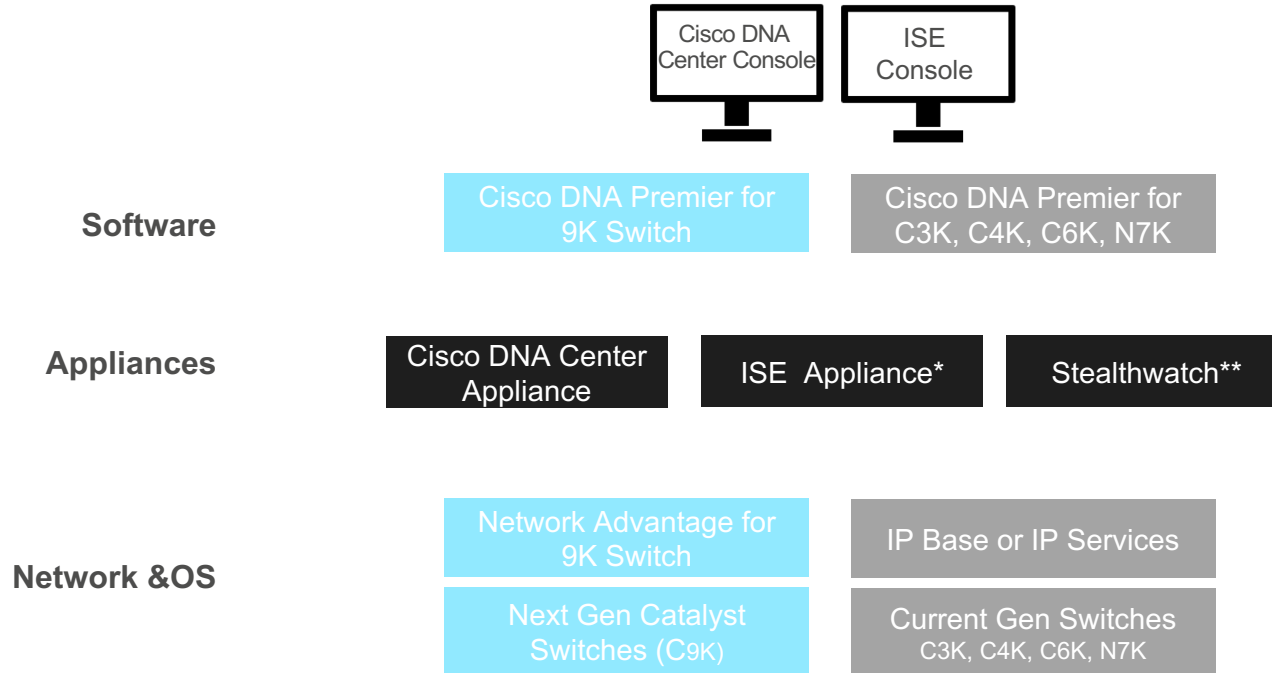

* ISE Appliance & Stealthwatch can be a physical or virtual appliance

**Stealthwatch management console and flow collector virtual edition is included in DNA Premier

What You Need for Base Automation & Monitoring

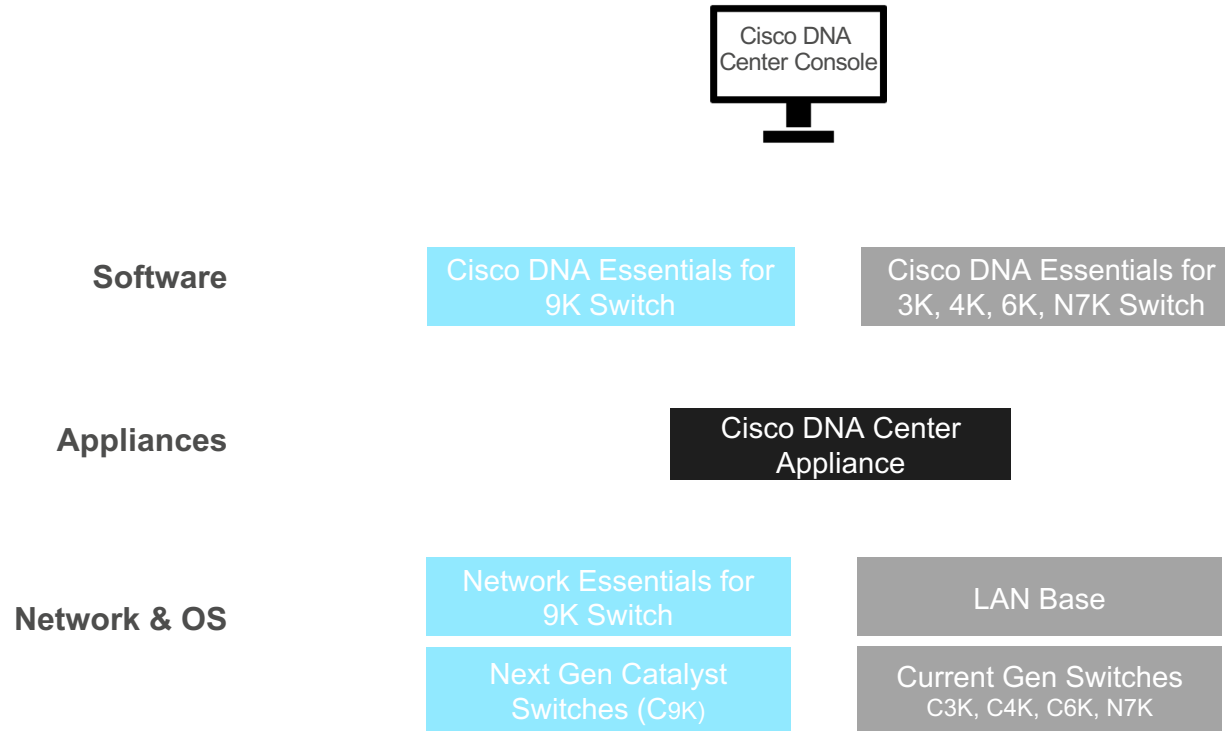

* ISE Appliance can be a physical or virtual appliance

Switching Enterprise Agreement Perspective

Cisco Enterprise Agreement

Cross-portfolio Buying Platform

Easy to Buy



Uniform Platform Structure

for new enrollments



Easy to Buy

Access to Add-ons
within enrollments



Financial Predictability

Easy to Consume



True Forward:
No retroactive billing

Easy to Consume

Access to New Software Capabilities



On Demand Deployment

Easy to Manage



Know Where You Stand.

SW licenses, usage & allocation.



Easy to Manage

Co-termination of SW Licenses

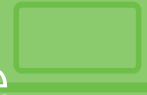

Company-wide Service Level Assurance

One Tech Partner for Network, Collaboration & Security

Cisco Enterprise Agreement

Cross-portfolio Buying Platform

Easy to Buy



Uniform Platform Structure

for new enrollments



Access to Add-ons

within enrollments



Financial Predictability

Easy to Consume



True Forward:
No retroactive
billing



Access to New
Software Capabilities



On Demand
Deployment

Easy to Manage



Know Where
You Stand.

SW licenses, usage
& allocation.



Co-termination of
SW Licenses



Company-wide
Service Level
Assurance

Cisco EA: Customer Qualifications

New or Existing Customers Looking For...



Cisco DNA Premier/Advantage for Switching EA Value



Get to Cisco DNA Value Faster! → Promos:

- Free inclusion of **IP Base to IP Services** upgrade
- 50% discounted **LAN Base to IP Base** upgrade

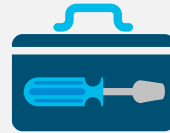

A Simplified, flat-rate upgrade SKU for all customers



Promotion:
'Ramp' schedule pricing* {1st 6 months free in EA}

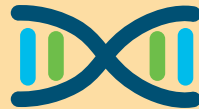

Promotion:
FREE 3 Cisco DNA-C Appliances with \$500K TCCV EA



Promotion:
2 Cisco DNA Accelerators & 2 Cisco DNA "Ask-the-Expert" sessions (with each free Cisco DNA-C Appliance)

* Ramp promotion only applicable to Brownfield customers

PLUS: Cross domain EA value proposition

Switching Migration – Value Comparison:

Customer owns 450 C3850-48P switches, with C1 Foundation for Switching with SWSS expiring

**Total EA Value:
\$6,534,680**

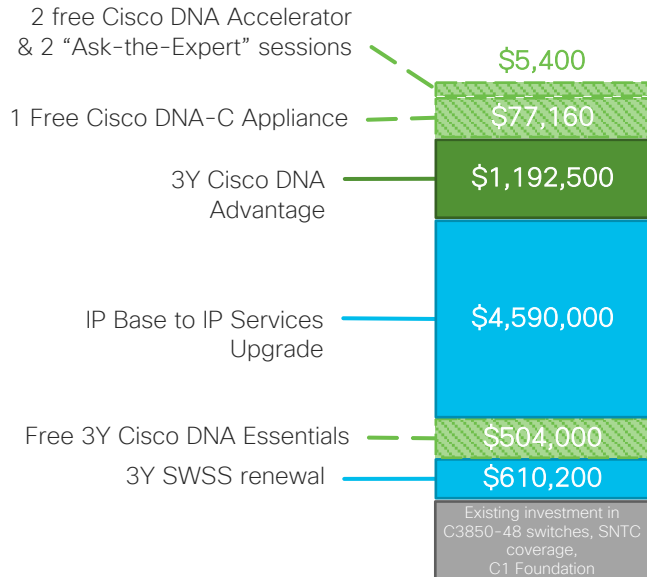

3Y Transaction Price = \$6,392,700

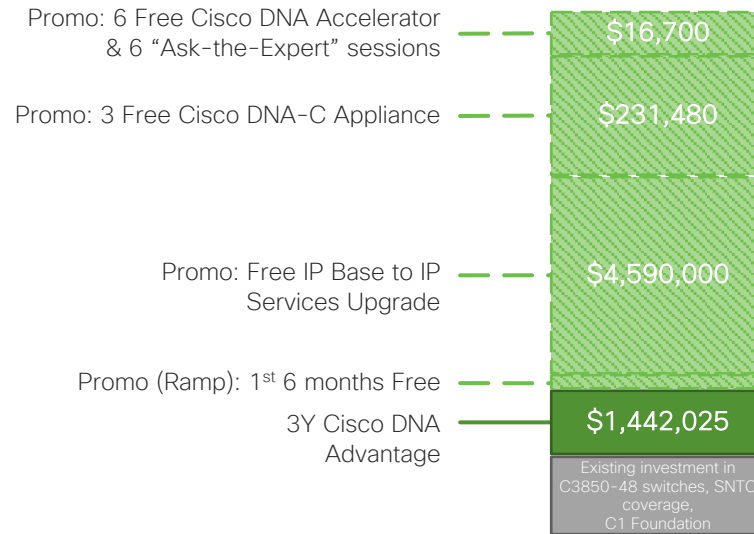

3Y EA Price = \$1,442,025

\$4,145,420 Additional Value with EA

Switching Migration – Value Comparison:

Customer owns 450 C3850-48P switches, 400 LAN Base & 50 IP Base licenses

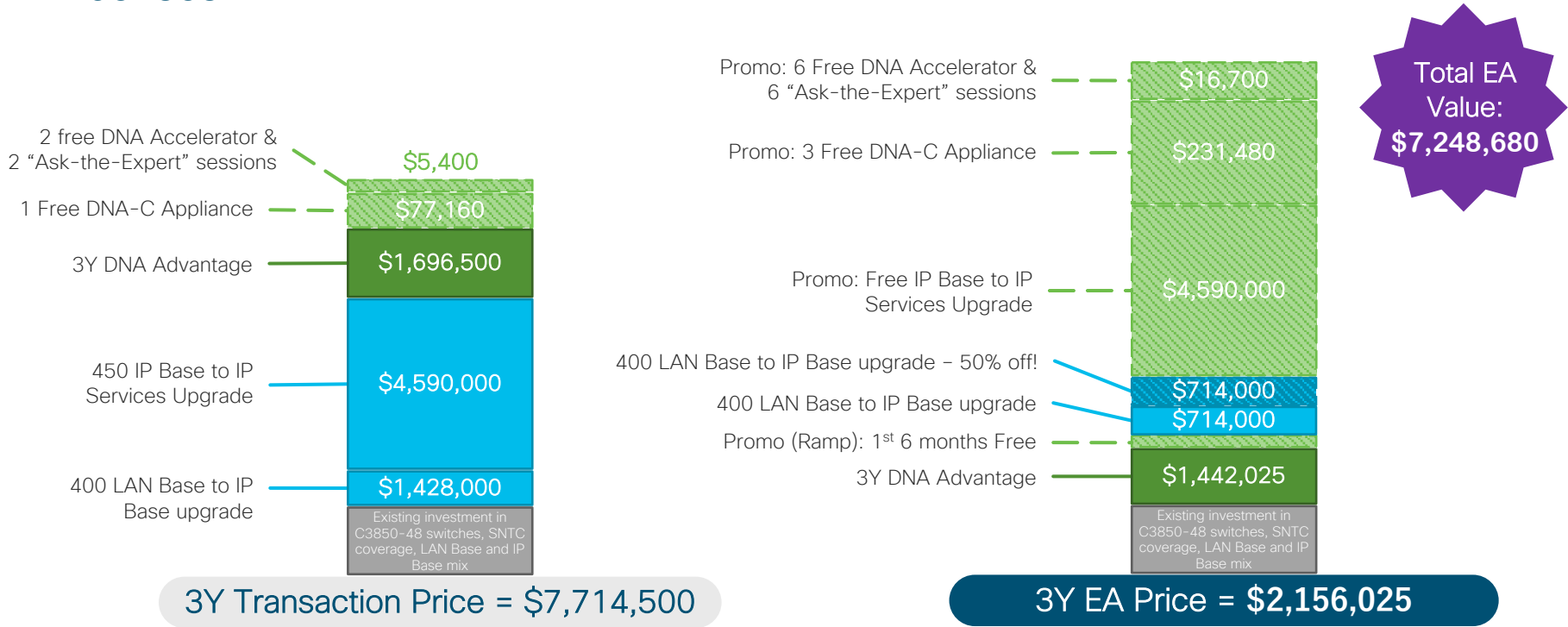

\$5,469,620 Additional Value with EA

Switching Greenfield – Value Comparison:

Customer owns 450 C9300-48P switches

Total EA Value:
\$248,180

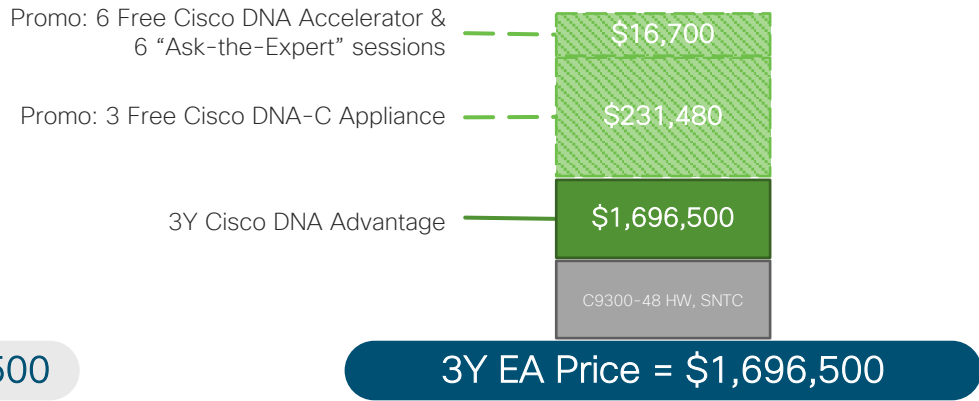
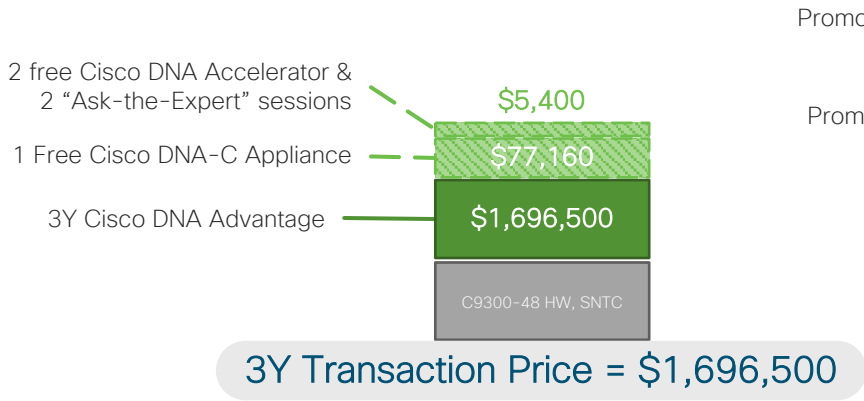

\$165,620 Additional Value with EA

Cisco DNA upgrade: To higher level Cisco DNA tier Enterprise Agreement (EA) method

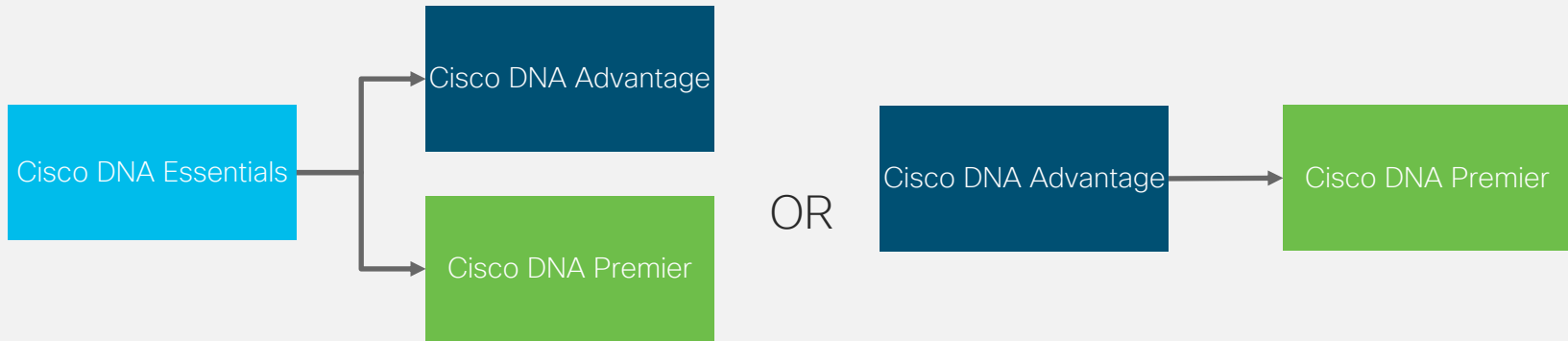

- 100% residual value for existing Cisco DNA subscriptions (any tier)
- Co-termining across Cisco DNA domain
- Install base assessment for the EA quote will cover any existing Cisco DNA subscriptions.
- Cisco DNA subscription residual value based on expected EA booking date (adjusted to actual booking date).

Technical Support Model

Technical Support Model

TS Product Level Support

Embedded Cisco Software Support Service (SWSS)
With Subscription
TAC, knowledge base access,
software downloads

Solution Support,
Smart Net Total Care
- or -
Partner Support Service
(Optional)

Cisco DNA Premier

Stealthwatch

ISE Plus

ISE Base

DNA Essentials / Advantage

Hardware with Network
Essentials / Advantage
(Catalyst 9k)

Cisco DNA Essentials/Advantage

Embedded support also
included for ISE /
Stealthwatch licenses
purchased A la Carte

Cisco DNA Essentials /
Advantage

Hardware with Network
Essentials / Advantage
(Catalyst 9k)

Ordering Experience

Single Hardware SKU for Cisco DNA simplifies Disti stocking

SNTC

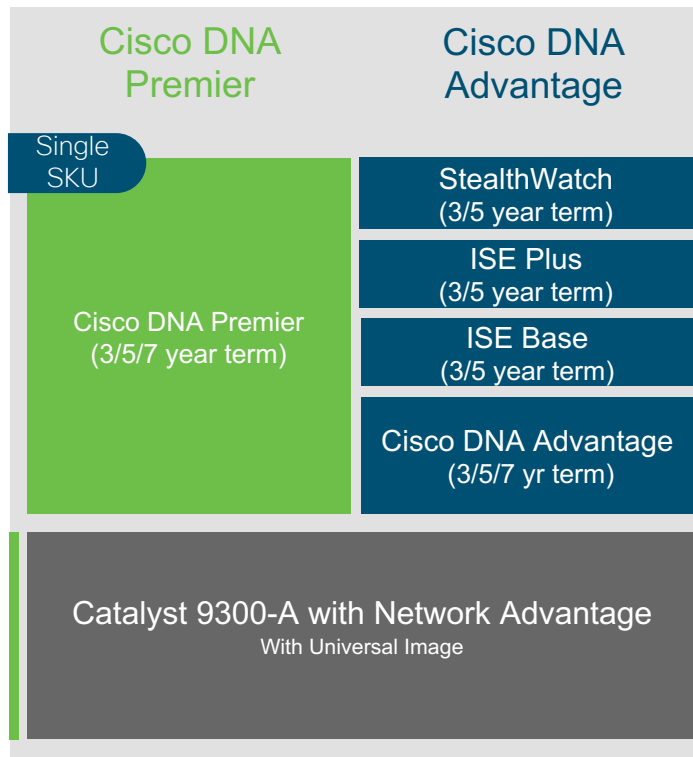
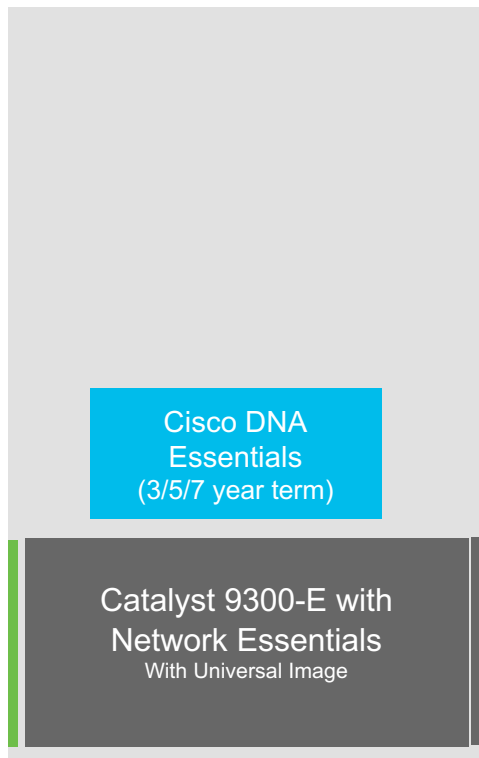

Disti Motion

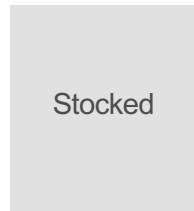
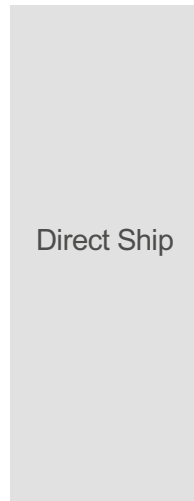

Smart Account

Cisco Smart Accounts – [Sign up today!](#)



Why Smart Accounts?

- Create one account
- Manage all software*
- View unused licenses
- Customize visibility



Why Smart Licenses?

Automatically registers

- Independent of hardware
- Traditional PAKs can be converted*



Why now ?

- Many data center software offers are Smart Account & Smart Licensing enabled
- Plans to ramp enablement of more offers

Call To Action



Learn more about Cisco DNA and Catalyst 9K

Lead with Cisco DNA Premier

Additional Resources: www.cisco.com/go/one

Contact your channel partner or Cisco sales team for more information

